

# 14mm T&G Herringbone Oak

## Installation Guidelines



**Furlong Flooring**

First choice flooring for every room

### PLEASE NOTE:

14mm T&G Herringbone Flooring is a professional product and requires a high degree of technical ability to be installed correctly. We always recommend a qualified and experienced professional should be responsible for installing this product.

### PRE INSTALLATION:

Your 14mm T&G Herringbone Flooring is a natural product and acclimatisation is required to ensure the best possible results. However, the warranty conditions dictate that the Engineered Wood Flooring is to remain in the sealed packaging before the date of installation.

#### Subfloor Preparation:

This type of flooring is suitable for installation on most types of flooring substrate, as long as its clean, dry and level, e.g. sand and cement screeds, timber floorboards, chipboard, plywood are all suitable). It is the responsibility of the flooring installer to check that the site condition is in a satisfactory state for the installation to take place including all moisture related readings.

#### Concrete & Screed Subfloors:

It is vital that the installer checks the moisture content of the concrete/screed to satisfy themselves that it is dry enough for the flooring to be installed. If measured directly with an appropriate moisture meter, the moisture content should not exceed 4% on a non-destructive moisture meter such as Tramex / Gravemetric weight percent measurement (2.5% CM for Concrete screed / 0.5% CM for Anhydrite screed) and the relative humidity of the air over the floor screed and should be between 45-55% R.H. @ a temperature of 18-21°C.

The floor screed must be levelled before installation to a tolerance of no more than a 3mm gap showing under a 3m straight edge.

#### Timber Subfloors:

Floorboards, O.S.B and Plywood, are all suitable subfloors for 14mm T&G Herringbone Flooring. This product is **NOT** suitable for installation directly onto joists or battens. Instead, a 20mm structural grade herringbone product should be used instead.

If your subfloor uses chipboard, we recommend stabilising this using a minimum of 6mm plywood before installing your Engineered Wood Flooring. The same level tolerance of 3mm applies.

Please Note: if installing on existing T&G flooring, make sure all old floorboards are secure and free of infestation'. We also recommend that your new flooring is installed at a 90° angle to the previous T&G flooring, this provides the necessary stabilisation required should any subsequent movement of either of the timbers should occur.

### PRODUCT USE:

14mm T&G Herringbone Flooring can be installed:

- On or above ground level (not suitable for use in basements)
- In well ventilated and dry areas, providing the area falls in line with the Climate Control section of these instructions.

- Using either the Glue-Down or Nail-Down method of installation.
- Over a plywood or concrete subfloor.

This floor should **NOT** be installed in bathrooms or laundry rooms. Use in either of these applications will void the product warranty. This T&G Herringbone Flooring is for indoor use only.

### PLEASE READ THESE INSTRUCTIONS COMPLETELY BEFORE BEGINNING THE INSTALLATION.

The following instructions must be used to install this Herringbone Flooring. Failure to do so may result in voiding the product warranty.

### INSTALLERS / OWNERS RESPONSIBILITY:

We only use the best natural materials to manufacture our flooring. As wood is a natural product, you can expect changes in colour, grain and appearance and other visual imperfections between each of the boards - No two planks will have the same characteristics.

We manufacture our products by following the accepted industry standard which outlines that defective boards must not exceed 5% of the full pack. These defects may be the result of manufacturing or naturally occurring characteristics of the material.

We recommend that a minimum of 10% for cutting and 5% for visual grading should be added to your total square meterage when calculating the quantity of flooring required.

**PLEASE NOTE:** If your room is not of equal proportions, the percentages of waste may be different to what we have outlined above - This is an approximation.

Before the installation begins; it is the joint responsibility of the installer and owner/customer of the site to conduct a thorough site inspection before any flooring is installed.

When carrying out the pre-installation inspection please pay close attention to the following aspects:

- Quality of Manufacturing
- Finish
- Colour Grading

If specific boards are deemed unacceptable, please exclude these boards from the installation process and check with your supplier on the suitability of the product. Boards that remain as part of the installation are considered to have been accepted by both installer and owner (even if the owner is not present at the time of installation).

It is the sole responsibility of the flooring installer to conduct thorough checks of the site, subfloor, installation tools and materials to ensure they meet or exceed the acceptable industry standards for installing hardwood flooring. We accept no responsibility for problems arising from incorrect or improper site preparation or

# 14mm T&G Herringbone Oak

## Installation Guidelines



**Furlong Flooring**

First choice flooring for every room

installation procedures.

### **SITE PREPARATION:**

Before installing your new floor, please ensure that the following points are addressed:

#### Installation in a new build construction

- Installation of all external windows and doors have been carried out. (This includes doors from the home to attached garages, failure to have these in place can affect the ambient temperature of adjoining rooms.)
- All concrete, masonry, plastering, drywall, texturing, painting and other wet work is complete and thoroughly cured and dry.
- Basements and crawl spaces are dry. Crawl spaces must have no standing water; crawlspaces must also have a vapour barrier and adequate ventilation that meet local building codes.
- Gutters and downspouts are in place, directing water away from the building.
- HVAC systems are fully operational, enabling heat and humidity levels to be controlled and maintained throughout the home.
- The Subfloor has been prepared correctly for installation.

#### Installation in an Existing Home (renovation)

If you are planning to install Herringbone Flooring in an existing home as part of a home renovation or remodel, the same principles apply to that of a new build construction. Please ensure all wet work (painting, wallpapering, texturing) is completed and thoroughly dry before commencing with the flooring installation.

In addition to the new build principles:

- Remove all furniture, artwork and other valuables from installation area.
- Remove any skirting board and mouldings.
- Undercut door frames
- Remove all existing flooring and underlay, if necessary

#### Underfloor Heating

This flooring can be used with water based embedded Underfloor Heating systems, but we recommend consulting your UFH instruction guidelines before installing to ensure the correct system is in place before the wood floor is installed.

The flooring installer should ensure the system has been correctly tested and is operational before commencing the installation of the flooring. Failure to do so can cause additional problems because of the wide range of temperatures the flooring is subjected to.

Always turn off the Underfloor heating system 24 hours prior to installation and allow it to cool fully.

Once the installation is completed, wait 48 hours before turning the system back on, this gives any adhesive used the time to fully cure.

When its time to turn the system back on, do so in small increments of 5°C each day until you reach your desired room temperature. Do **NOT** turn the system straight up to the maximum, as this cause the timber to dry out quickly and

cause the floor to split or crack.

Maximum allowed contact temperature should not exceed 26°C, this is to the base of the board, not the top surface. Please note that loose carpets/rugs insulate the surface by around 2°C!

Important: Follow the heating regulation recommendations given by the underfloor heating system supplier.

#### Climate Control

Climate control is essential when it comes to wood flooring. The conditions at the job site must be maintained with the air temperature between 18-24°C and relative humidity at 45-55% before, during and after the installation. The flooring should not be delivered to the site until these conditions have been met and maintained for 1 week for plywood subfloors and 2 weeks for concrete subfloors.

Following the installation, these temperature and relative humidity conditions should be maintained at all times to ensure you get the best out of your new floor. See Warranty for more details.

If the temperature and humidity conditions meet the manufacturer's guidelines, the material should then be delivered to the site. When stacking boxes, ensure that boxes are cross stacked to allow for proper airflow between each box during the acclimatisation period. Do not open the boxes; leave closed until ready to commence the installation and open each one as required when performing the pre-installation checks.

#### Colour Racking

Real Wood Flooring contains natural variations in colour and grain pattern. To prevent colour grouping or repetitive patterns in the finished floor surface, We recommend unboxing 3/4 cartons to get a sense of the range of colour variation and arrange the planks to achieve a satisfactory appearance. When sorting boards, pay close attention to visible manufacturing defects and any transport damage (if applicable). Once a plank has been installed, these are considered to have been accepted by the customer and are not eligible for exchange or replacement (See Warranty for more details).

#### Expansion Space

Wood flooring expands and contracts with changes in ambient temperature and humidity. To allow for this, during installation please leave an 18mm expansion space around the entire perimeter of the floor between the flooring and the walls. Also leave expansion space where the flooring meets doorways and any vertical obstacle, such as stairs, pipes, tiles and cabinets. These will be covered by skirting boards or scotia's at the end of the installation process.

**NOTE:** In climates with extreme variations in humidity, or in large installations (>80m<sup>2</sup>), a larger expansion space may be required.

#### **CLEANING & MAINTENANCE**

Once the installation of your hardwood floor is complete, it is essential to ensure you familiarise yourself with the correct and safe ways to clean and maintain the surface to avoid any

# 14mm T&G Herringbone Oak

## Installation Guidelines



**Furlong Flooring**

First choice flooring for every room

potential damage.

### Daily Cleaning

For day-to-day cleaning, it is essential to dust your hardwood floors with a microfibre mop or cloth each day to prevent any scratches and surface damage. Microfibre cleaning pads use static electricity to trap dirt, particles and other household allergens. Dusting the surface will remove any particles of dust and grit that may appear from footwear, chair legs and will contribute to preventing the floor from long-term damage. Household brushes may also be used, but please be aware that these can push the dirt around and may potentially cause scratches to the surface of the floor.

### Weekly Cleaning

On a weekly basis, we recommend giving your hardwood floor a vacuum or damp mop to get rid of more stubborn stains or debris that may have dried onto the surface. Keep any protruding parts of the vacuum away from the surface of the floor as this can cause damage. Any excess water should be removed from the floor immediately and never pour water directly onto the floor's surface as this can cause swelling, warping, splitting and even joint separation and not only reduce your floor's lifespan, it will also most likely void any manufacturers' warranty.

### Ongoing Maintenance

For a more in-depth clean, we recommend giving your floor a deep clean 3/4 times per year to ensure the floor is well protected from day-to-day living. As we offer many different types of finishing materials on our flooring, we recommend speaking to your retailer who will be able to advise on the correct maintenance products for your flooring depending on its finish, in accordance with the description on the product end label.

### Cleaning Tips & Tricks

- Use a good quality doormat at entrances & exits to avoid dirt and debris entering the home.
- Always use appropriate felt pads on chairs, tables and any other furniture to minimise indentations.
- For drink spillages, these must be cleaned up immediately.
- Avoid using water and vinegar or soap-based cleaners, as these will dull the floor's finish over time.
- Do **NOT** use Steam Cleaners on your hardwood floors as these also put heat and excessive water on your floor.

# 14mm T&G Herringbone Oak

Installation Guidelines



**Furlong Flooring**

First choice flooring for every room

## INSTALLATION OF HERRINGBONE BOARDS (BASED ON A HERRINGBONE PATTERN)

### Choosing your Installation Method:

Fixing Herringbone Flooring can be done in two ways;



#### Glue Down

The Glue Down Method uses a moisture-cured urethane adhesive that has been specially formulated for installing hardwood flooring.



#### Nail Down

Herringbone Flooring can also be nailed to a wooden subfloor. For a guide on how to nail this product, please refer to the guide on our website.

Always refer to the adhesive manufacturers' guidelines for how to install, the correct tools to do so and any curing and drying times. For installations where your subfloor is outside of the guidelines outlined in our Subfloor Preparation section, a suitable moisture suppressant should always be used.

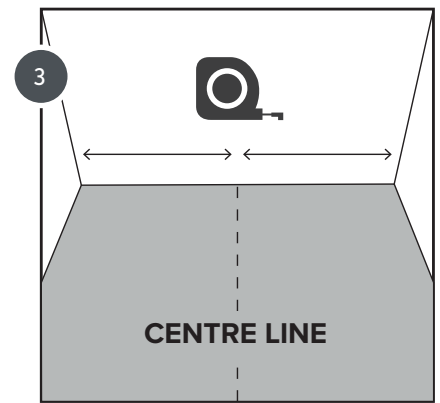
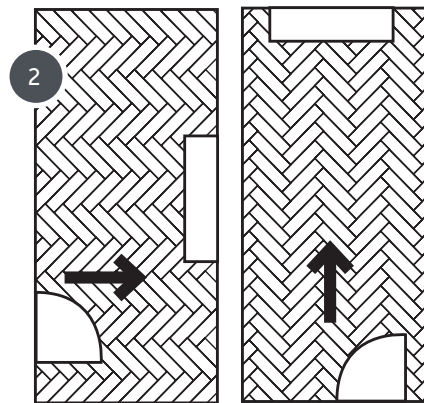
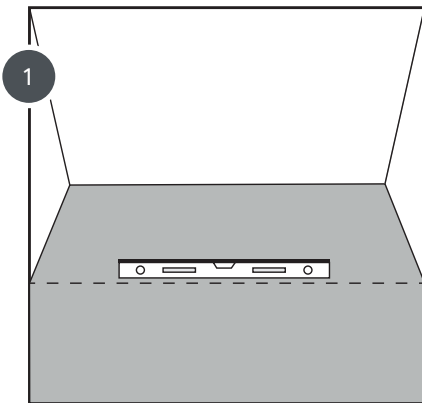

### Step 1

Before beginning the installation process ensure that:

- The subfloor is suitable and levelled correctly for the above product.
- Verify moisture content of both subfloor and the planks are within the allowable limits and take note of these values.
- Check that the room temperature and relative humidity meet the specific requirements outlined in the Climate Control section.
- A suitable underlay product has been used for the room type (if required.)

### Step 2

Determine the layout of the floor and which way you'd like the pattern to flow throughout the room. Typically we recommend that the pattern should run the length of the room, but in some cases, it can be altered according to accommodate for fixed features such as a fireplace, main entranceway or light source.

### Step 3

Once the layout of your patterned flooring is agreed, start by marking a centre line across the floor in the same way the pattern will flow.

Precise measurements are essential when laying a Herringbone pattern. Always verify measurements and check row alignment frequently to ensure an accurate and even pattern is consistent across the room. Failing to do so may cause stepping between boards and a break down in the desired pattern.

# 14mm T&G Herringbone Oak

Installation Guidelines



**Furlong Flooring**

First choice flooring for every room

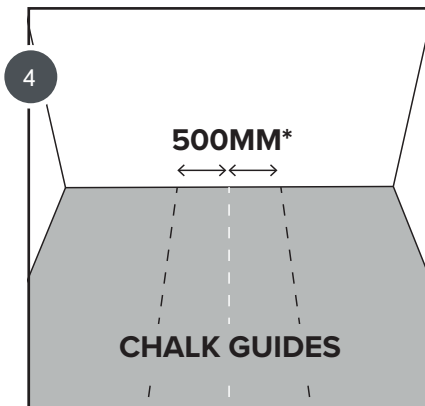

## Step 4

Once the centre line is in place, snap a parallel chalk line 500mm to the left of the centre line and another 500mm to the right\*. (Shown in the diagram) These serve as guides for the outer edges of the first two rows, and the corner of each board should be checked against this once installed to ensure it is parallel to the centre chalk guideline.

\* Measurements are subject to board size and sizes quoted may need to be altered to suit some floors.

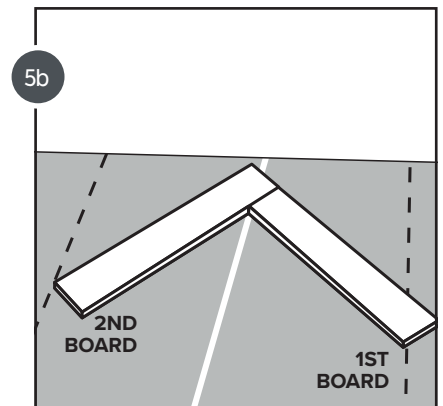
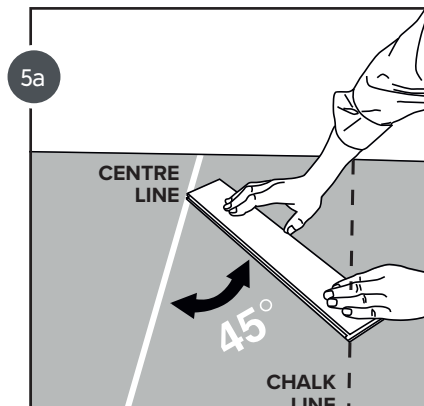

## Step 5 A / B

Once all the guides are in place, you are now ready to begin the installation process. Start by dry fitting the first board at a 45-degree angle (5A) touching the centre line and intersecting one of the chalk lines. Repeat this process with a 2nd board so that you have a V shape arrangement of boards (5B).

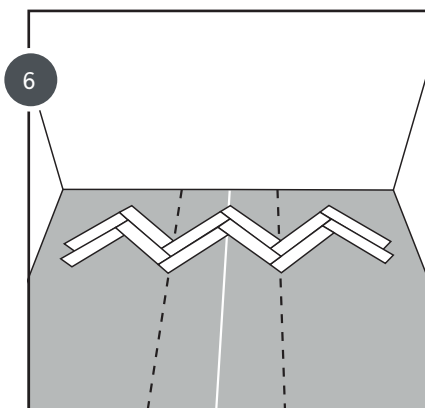

## Step 6

Dry fit additional boards to make up the first two rows across your room. Ensuring the pattern is correct and stays square with the centre line and left/right markings.

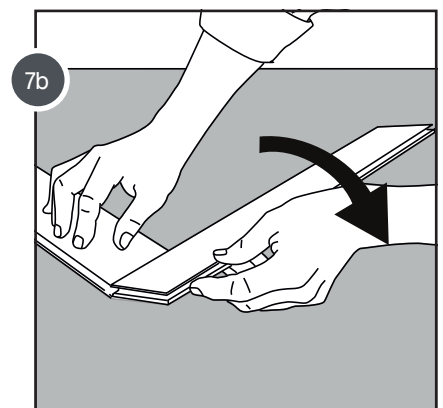
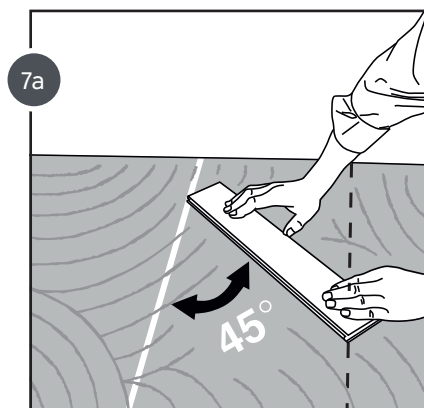

## Step 7 A / B (Stick Down Method)

If the pattern looks correct, fix these two rows in place, starting from the chalk line, spread adhesive over a reasonable working area (A) and set the first right-hand board in place with the groove side snug to the centre guide, and the butt ends aligned with the right chalk guide. Then place the first left-hand board in position engaging the upper butt joint with that of the right-hand board (B) and making sure the opposite end of the left-hand board touches the other chalk line (If nailing apply the layout principles).

# 14mm T&G Herringbone Oak

Installation Guidelines



**Furlong Flooring**

First choice flooring for every room

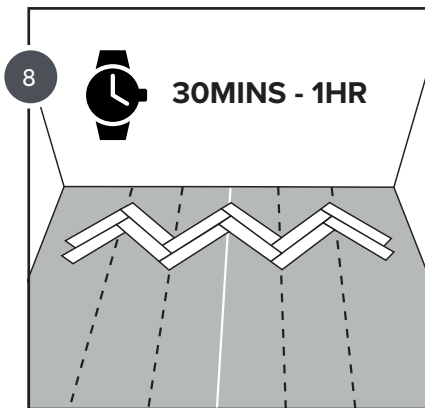

## Step 8

Allow the first two rows to cure fully for 30mins to 1hr (if using adhesive) before continuing with the installation, as the movement of boards can lead to the floor pattern being disrupted further into the installation.

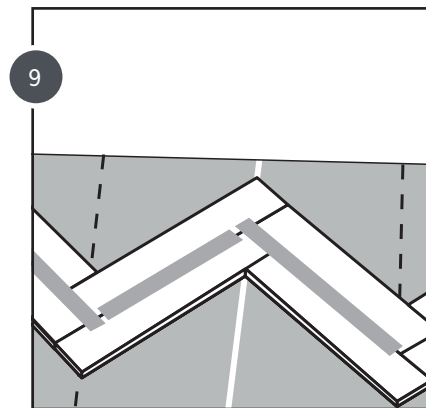

## Step 9

To prevent boards from shifting after they have been set into place, strap them with low tack masking tape. (Do not use regular masking tape as it may leave a residue of adhesive on the surface.)

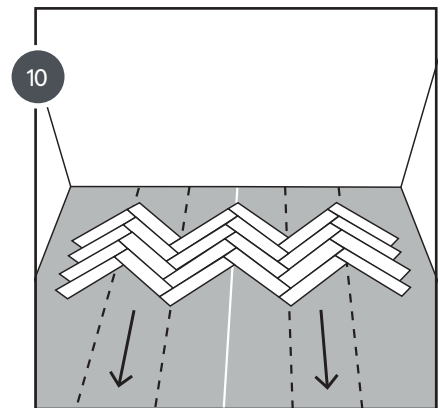

## Step 10

Continue with the installation ensuring the tongue on each board follows the correct direction. Check measurements and row alignment frequently to ensure that your rows are staying true and square.

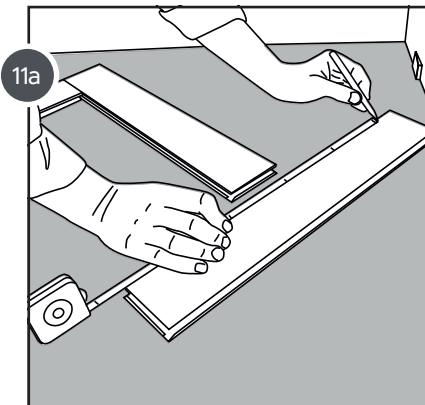

11a

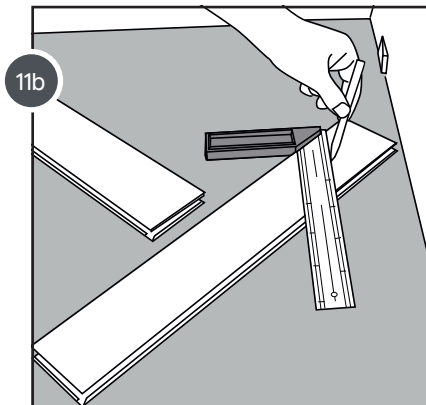

11b

## Step 11 A / B / C / D

Once the majority of the planks are installed, and you're ready to backfill the cut boards around the perimeter of the room. Work around the room and measure each board individually (11A), use a straight edge to mark your cut line (11B) and cut using a saw (11C) filling in each of the gaps as you go (11D).

Remember only to apply enough adhesive for the smaller section to avoid spillage onto the freshly laid planks.

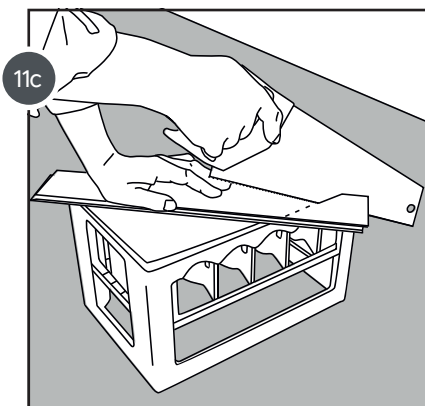

11c

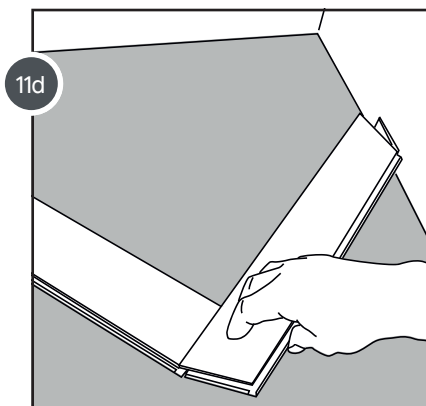

11d

# 14mm T&G Herringbone Oak

Installation Guidelines



**Furlong Flooring**

First choice flooring for every room

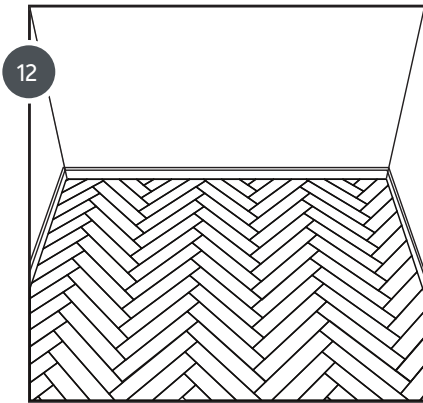

### Step 12

Install mouldings and profiles as required. Ensure skirting or mouldings are fixed to the wall and not the floor.

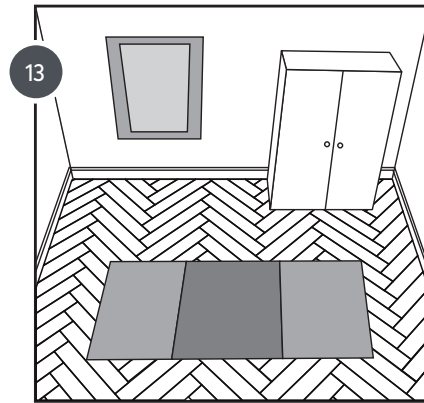

### Step 13

Allow 24 hours curing time before moving any furniture or appliances onto the newly laid floor.

### Alternative ways of installing Herringbone Flooring

Along with a traditional herringbone pattern, Herringbone Flooring may also be installed in a variety of patterns to achieve many different styles. Speak with your professional installer on how to achieve alternative patterns.

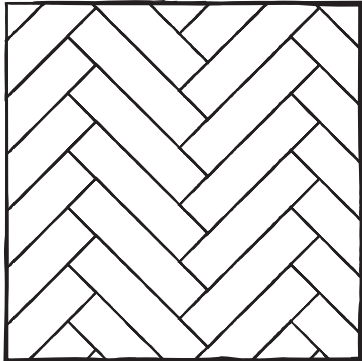

Single Herringbone

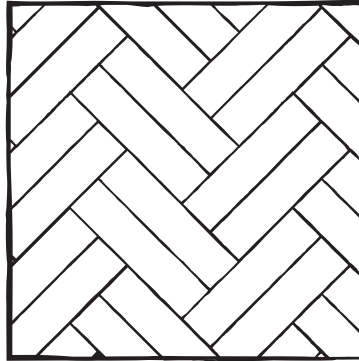

Double Herringbone

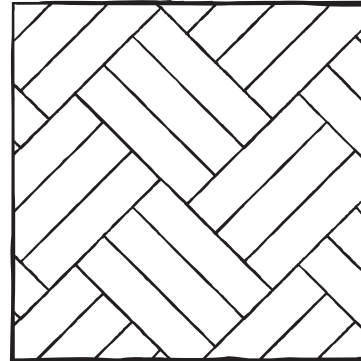

Triple Herringbone

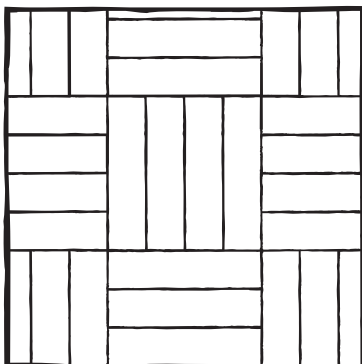

Basket Weave

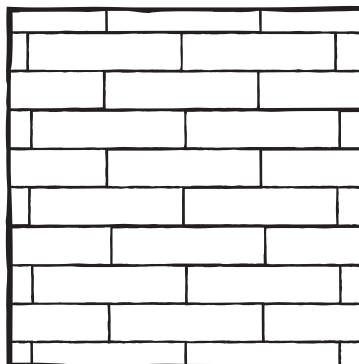

Subway

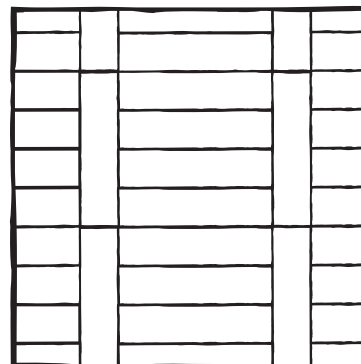

Ladder

# 14mm T&G Herringbone Oak

## Installation Guidelines



**Furlong Flooring**

First choice flooring for every room

### UK WARRANTY

1. The manufacturer is responsible for manufacturing defects.
2. This product must be installed correctly according to the outlined above instructions. The warranty covers regular use. The warranty does not include the use of this product in damp and wet spaces, such as conservatories, bathrooms and kitchens.
3. Planks showing visible defects should not be used as part of the installation. It is the responsibility of the owner/fitter to deselect these boards at the time of installation. These boards are to be allowed for in the 5% waste tolerance. Boards with visible defects that are installed are excluded from this warranty. Colour and grade de-selection is not allowed for, as this is a personal choice and not a defect in the manufacturing of the product.
4. Always check all boards to ensure the board dimensions are accurate before installing. Off-cut boards should not always be classed as waste, short or longer pieces can both be used around the perimeter of the floor if permitted.
5. Finished flooring, i.e. lacquered, stained, oiled, brushed, or other finished flooring is subject to normal wear and shall not be covered by this warranty, i.e. if you don't maintain the floor correctly, the warranty is null and void.
6. Excluded under this warranty are scratches, heavy impacts, humidity, and damage caused by incorrect use or lack of correct maintenance.
7. If you have a defect, which falls under the conditions mentioned in this warranty, you should report this to your dealer in writing within 14 days after detecting the defect. In your letter, you should include a copy of the original invoice.
8. This warranty only relates to the planks supplied, and consequently, it does not include labour costs, the costs of additional material and any other consequential loss.
9. In case of a dispute arising from the warranty, either party may call upon an independent expert to render binding advice. If this clause is applicable, the cost is to be agreed in writing with all parties involved in advance.
10. Where the warranty applies, the manufacturer or its distributors will replace the faulty product. In case the product in question is no longer available, we will ensure replacement of an alternative product of the same quality.
11. This warranty shall apply only to the original owner/purchaser of the wood floor.

### WARRANTY WILL NOT BE APPLICABLE IF:

1. The floor has not been installed following the correct methods outlined in the instructions by a qualified installer.
2. The faults were noticed and ignored before the floor was installed.
3. Defects and faults having arisen due to dampness or water damage or any other causes as a result of negligence or force majeure.
4. Defects and faults have been caused by improper use or negligence and failure to use the product for its intended purpose, as well as having been caused by having disregarded the instructions for installation, use and maintenance.
5. Visual faults having arisen as a result of any deformation of the boards due to changed climate conditions, any variations in colour due to the influence of sunlight and the effects of normal ageing and wear and tear of the finishing coat.
6. Stains or mechanical damage to the surface (scratches and dents) resulting from improper treatment during transport, storage and any damage caused by stiletto heels, furniture, stones, sand and pets.

### MANUFACTURING TOLERANCE

ENGINEERED HARDWOOD FLOORS ARE A NATURAL PRODUCT AND AS SUCH ARE SUBJECT TO MANY VARIANCES IN COLOUR AND CHARACTER IN EACH INDIVIDUAL PIECE OF FLOORING, WE ALWAYS THEREFORE RECOMMEND YOU WORK FROM 3-4 PACKS OF FLOORING AT A TIME IN ORDER TO GET THE BEST NATURAL COLOUR MIX. AS SUCH A TOLERANCE OF 5% SHOULD BE ALLOWED FOR THE DESELECTION OF ANY MATERIAL DEEMED UNSUITABLE FOR INSTALLATION. THIS PRODUCT IS PRODUCED WITH A MANUFACTURING TOLERANCE OF + OR - 1.5% ON THE DIMENSION OF THE BOARD AND IN LINE WITH SPECIFIED TIMBER MANUFACTURING GUIDELINES, AS SUCH ANY ITEMS OUT OF TOLERANCE SHOULD BE DISMISSED AS PART OF THE 5% MANUFACTURING TOLERANCE.